

DMAPF: A Decentralized and Distributed Solver for Multi-Agent Path Finding Problem with Obstacles

Poom Pianpak

Tran Cao Son

New Mexico State University
Las Cruces, New Mexico, USA

{ppianpak, tson}@cs.nmsu.edu

Multi-Agent Path Finding (MAPF) is a problem of finding a sequence of movements for agents to reach their assigned location without collision. Centralized algorithms usually give optimal solutions, but have difficulties to scale without employing various techniques – usually with a sacrifice of optimality; but solving MAPF problems with the number of agents greater than a thousand remains a challenge nevertheless. To tackle the scalability issue, we present *DMAPF* – a decentralized and distributed MAPF solver, which is a continuation of our recently published work, *ros-dmapf* [10]. We address the issues of *ros-dmapf* where it (i) only works in maps without obstacles; and (ii) has a low success rate with dense maps. Given a MAPF problem, both *ros-dmapf* and *DMAPF* divide the map spatially into subproblems, but the latter further divides each subproblem into disconnected regions called areas. Each subproblem is assigned to a distributed solver, which then individually creates an abstract plan – a sequence of areas that an agent needs to visit – for each agent in it, and interleaves agent migration with movement planning. *Answer Set Programming*, which is known for its performance in small but complex problems, is used in many parts including problem division, abstract planning, border assignment for the migration, and movement planning. *Robot Operating System* is used to facilitate communication between the solvers and to enable the opportunity to integrate with robotic systems. *DMAPF* introduces a new interaction protocol between the solvers, and mechanisms that together result in a higher success rate and better solution quality without sacrificing much of the performance. We implement and experimentally validate *DMAPF* by comparing it with other state-of-the-art MAPF solvers and the results show that our system achieves better scalability.

1 Introduction

Robots have been making their way into human life. From household robots to self-driving cars and industrial robots, it is expected that the number of robots will keep increasing in the future. To cope with such growth, robot controlling systems need to be designed with scalability in mind. We took an inspiration from autonomous warehouse systems^{1,2} where the retrieval and storage tasks are done autonomously by mobile robots. When the system receives an order, it assigns a set of robots to retrieve shelves containing the products to a human operator for fulfillment of the order, then store the shelves back in their appropriate place.

In this paper, we only consider the problem of finding a plan for agents to reach their assigned location (i.e., goal) without collision. The problem is called *Multi-Agent Path Finding* (MAPF) and will be formally introduced in Section 2.1. Most existing MAPF algorithms are centralized (i.e., having a central unit overseeing the entire solving process) such as *WHCA** [13], *asprilo* [6], and *CBS* [12]. While there are attempts to improve the scalability of centralized algorithms using various techniques, such as

¹<https://amazonrobotics.com>

²<https://locusrobotics.com>

abstraction (e.g., planning for each agent independently then combine the partial plans to obtain the solution – while resolving any conflict), dealing with MAPF problems with a large number of agents (greater than a thousand) still remains a challenge. We have designed a decentralized and distributed MAPF algorithm, named *DMAPF* – **D**istributed **M**ulti-**A**gent **P**athfinder – with scalability in mind. *DMAPF* is able to take advantage of distributed computing to cope with the possibility of having an ever-increasing problem size. An input problem to *DMAPF* is encoded in *answer set program* as generated by the *AS-PRILO* project [6] and solved using mainly the *answer set programming*, which will be introduced in Section 2.2. The communication between distributed components in *DMAPF* is facilitated by the *Robot Operating System* (ROS), which will be introduced in Section 2.3.

DMAPF is an improvement over our original system, *ros-dmapf* [10]. We address the issues in *ros-dmapf* where it (i) only works in maps without obstacles; and (ii) has a low success rate with dense maps. *DMAPF* shares the same idea with *ros-dmapf* in that, given a MAPF problem, it divides the problem spatially and assigns each divided subproblem to a distributed solver, which is a ROS node. The difference is that *DMAPF* also further divides each subproblem into disconnected regions called areas. This, together with a few other changes, allow *DMAPF* to deal with having obstacles. The details of problem division will be explained in Section 3.1. After the subproblems have been distributed, each solver individually creates an abstract plan – a sequence of areas that an agent needs to visit to reach the area that contains its goal – for each agent in the given subproblem. The details of abstract plan creation will be explained in Section 3.2.1. After the plans have been made for every agent, the solvers interleave communicating with neighboring solvers to send/receive migrating agents (details in Sections 3.2.2, 3.2.3, and 3.2.5) with movement planning (details in Section 3.2.4) along each round. This differs from *ros-dmapf* where it does the communication from beginning to end first, then finds a movement plan for each round in a single attempt. If *ros-dmapf* is unable to make a plan during the movement planning phase, it would be difficult to adjust the border assignment since assignments for the next rounds have already been agreed upon, whereas *DMAPF* can easily adjust the assignment and retry. This, together with changes in migration protocol, allow *DMAPF* to achieve a higher success rate and better solution quality than *ros-dmapf*. *DMAPF* has been implemented and compared with other state-of-the-art solvers. Section 4 shows results of the comparison. Section 5 concludes with discussion on the results, advantages, limitations, and future work.

2 Background

2.1 Multi-Agent Path Finding Problem

A *Multi-Agent Path Finding* (MAPF) problem can be defined as a quadruple $P = (G, A, S, T)$, where $G = (V, E)$ is a graph such that V is a set of vertices corresponding to locations in the graph, and $E \subseteq V \times V$ denotes edges between two locations; A is a set of agents; and $S \subseteq A \times V$ and $T \subseteq A \times V$ denote start and goal locations of the agents, respectively.

Agents can move from v_1 to v_2 where $v_1, v_2 \in V$ if $(v_1, v_2) \in E$, under the restrictions: (a) two agents cannot swap locations in a single time step; and (b) each location can be occupied by at most one agent at a time. A path for an agent a is a sequence of vertices $\alpha_a = \langle v_1, \dots, v_n \rangle$ if (i) agent a starts at v_1 (i.e., $(a, v_1) \in S$); and (ii) there is an edge between any two subsequent vertices v_i and v_{i+1} (i.e., $(v_i, v_{i+1}) \in E$), or they are the same vertex (i.e., $v_{i+1} = v_i$). An agent a completes its order $T_a = \{v \mid (a, v) \in T\}$ via a path $\alpha_a = \langle v_1, \dots, v_n \rangle$ if $T_a \subseteq \{v_1, \dots, v_n\}$. A *solution* of a MAPF problem P is a collection of paths $Sol = \{\alpha_a \mid a \in A\}$ such that all orders in T are completed.

In our work, we assume that (i) each agent has a different start location (i.e., $\forall_a \exists_v ((a \in A \rightarrow (a, v) \in$

$S) \wedge \neg \exists_{\hat{v} \neq v}((a, \hat{v}) \in S) \wedge \neg \exists_{\hat{a} \neq a}((\hat{a}, v) \in S))$; (ii) each agent either has no goal or has a distinct goal location (i.e., $\forall_{a_1, a_2, v}((a_1, v), (a_2, v) \in T \rightarrow a_1 = a_2)$); (iii) each agent is at its goal at the last time step (i.e., $\forall_{a, v}((a, v) \in T \wedge \alpha_a = \langle v_1, \dots, v_n \rangle) \rightarrow v = v_n$); and (iv) the graph is grid-based. These assumptions are common among most multi-agent path finding solvers.

2.2 Answer Set Programming

Let us provide some general background on *Answer Set Programming* (ASP). Consider a logic language $L = \langle C, P, V \rangle$, where C, P, V are sets of constants, predicate symbols, and variables, respectively, and the notions of terms, atoms, and literals are traditional.

An *answer set program* Π is a set of *rules* of the form

$$c \leftarrow a_1, \dots, a_m, \text{not } b_1, \dots, \text{not } b_n \quad (1)$$

Each a_i and b_i is a literal from L , and each *not* b_i is called a negation-as-failure literal (or naf-literal). c can be a literal or omitted. A program is a *positive program* if it does not contain naf-literals. A *non-ground rule* is a rule that contains variables; otherwise, it is called a *ground rule*. A rule with variables is simply used as a shorthand for the set of its ground instances from the language L . If $n = m = 0$, then the rule is called a *fact*. If c is omitted, then the rule is called an *ASP constraint*.

A set of ground literals X is *consistent* if there is no atom a such that $\{a, \neg a\} \subseteq X$. A literal l is true (resp. false) in a set of literals X if $l \in X$ (resp. $l \notin X$). A set of ground literals X satisfies a ground rule of the form (1) if either of the following is true: (i) $c \in X$; (ii) some a_i is false in X ; or (iii) some b_i is true in X . A solution of a program, called an *answer set* [7], is a consistent set of ground literals satisfying the following conditions:

- If Π is a *ground program* (i.e., a program whose rules are all ground), then its answer set S is defined by the following:
 - If Π does not contain any naf-literals, then S is an answer set of Π if it is a consistent and subset-minimal set of ground literals satisfying all rules in Π .
 - If Π contains some naf-literals, then S is an answer set of Π if it is an answer set of the *program reduct* Π^S . Π^S is obtained from Π by deleting (i) each rule that has a naf-literal *not* b in its body with $b \in S$; and (ii) all naf-literals in the bodies of the remaining rules.
- If Π is a *non-ground program* (i.e., a program whose rules include non-ground rules), then S is an answer set of Π if it is an answer set of the program consisting of all ground instantiations of the rules in Π .

The ASP language includes also language-level extensions to facilitate the encoding of aggregates (*min*, *max*, *sum*, etc.), range specification of variables, and allowing choice of literals. In ASP, one solves a problem by encoding it as an ASP program whose answer sets correspond one-to-one to the solutions of the problem [8, 9]. Answer sets of ASP programs can be computed using ASP solvers like CLASP [5] and DLV [3].

Early ASP rests upon a single-shot approach to problem solving – an ASP solver takes a logic program, computes its answer sets, and exits. Unlike this, recently developed multi-shot ASP solvers provide operative solving processes for dealing with continuously changing logic programs. For controlling such solving processes, the declarative approach of ASP is combined with imperative means. In *clingo* [4], this is done by augmenting an ASP encoding with C or Python procedures. The instrumentation includes methods for adding/grounding rules, setting truth values of (external) atoms, computing the answer sets of current program, etc.

2.3 Robot Operating System

The *Robot Operating System* (ROS) is an open-source framework designed for building robotics systems which is distributed in nature [11]. We adopt ROS because of its scalability and support for the development of heterogeneous clusters of software. ROS provides client libraries³ for software written in different languages (e.g., C++, Python, Lisp) to communicate.

A ROS system must consist of a *roscore* at a bare minimum, and may consist of multiple *ROS nodes*. A *roscore* is a set of prerequisites to run a ROS-based system, and it consists of a *ROS master* among a few other things. A ROS node is an individual process that does some computation. ROS nodes working together for a particular task may be organized as a *package*, and they can be on different networks. For a node n_1 to communicate with another node n_2 , n_1 first needs to locate n_2 via the ROS master, then n_1 can communicate directly with n_2 as a peer-to-peer network. There are mainly two forms of communication between ROS nodes:

1. *Publish-Subscribe* – nodes are connected via a *topic*, which is a named bus. A node sending (resp. listening to) messages on a topic is called a *publisher* (resp. *subscriber*). One node can both be a publisher and a subscriber on the same or multiple topics. A topic may have zero or more publishers and/or subscribers.
2. *Request-Response* – two nodes follow an RPC interaction through a *service*. A node that provides (resp. calls) a service is called a *service server* (resp. *service client*). There can only be one service server, but possibly multiple service clients for a single service. Calls from the service clients will be put into a queue and processed one-by-one.

3 Methodology

Algorithm 1 shows an overview of *DMPF*. The algorithm takes a MAPF problem P and the dimension $dx \times dy$ of desired subproblems as inputs, and produces the solution if it could find one. Line 1 divides the given problem P into smaller subproblems: P_1, \dots, P_n , and provides the *Links* information telling which pairs of *areas* within the subproblems are *connected* (i.e., there exists some border between them). This step will be explained in Section 3.1. The problem can also be divided by hand as *DMPF* does not put restrictions on how the subproblems have to be divided, i.e., they do not have to be rectangles of dimension $dx \times dy$. Lines 2-4 create solvers s_1, \dots, s_n as *ROS nodes* with the divided subproblem P_i as their input. How the solvers work together, which is the core of the algorithm, will be explained in Section 3.2. Solver s_1 has an extra responsibility, besides solving its own subproblem, to aggregate partial plans from all the solvers and create the solution as an output. Therefore, line 5 waits for s_1 to finish its own task of solving P_1 , combine partial plans from all the solvers, and produce the solution at line 6.

Figure 1 depicts an overview of a *DMPF* system. In there, the problem has been divided into subproblems P_1, P_2, \dots, P_n and each of them is an input to solvers s_1, s_2, \dots, s_n , respectively. All solvers have *Links* information telling which pairs of them are *connected*. They use this information as an abstract map to find abstract plans (details in Section 3.2.1). All solvers connect to *Track* topic to synchronize and exchange information to determine whether they have finished their work, or if not, which of them still have work to do. Each of them also provides a *Migrate* service for connected solvers to call if there is any robot that needs to move between them. Solver s_1 provides *Aggregate* service for the other solvers

³Visit <http://wiki.ros.org/Client%20Libraries> for a full list of ROS client libraries

Algorithm 1 *DMAPF***Input:** P, dx, dy **Output:** A solution or none

- 1: $(P = \{P_1, \dots, P_n\}, Links) \leftarrow Divide(P, dx, dy)$
- 2: **for each** $P_i \in P$ **do**
- 3: Create solver s_i for solving P_i {in parallel}
- 4: **end for**
- 5: Wait for s_1
- 6: **return** $s_1.solution$

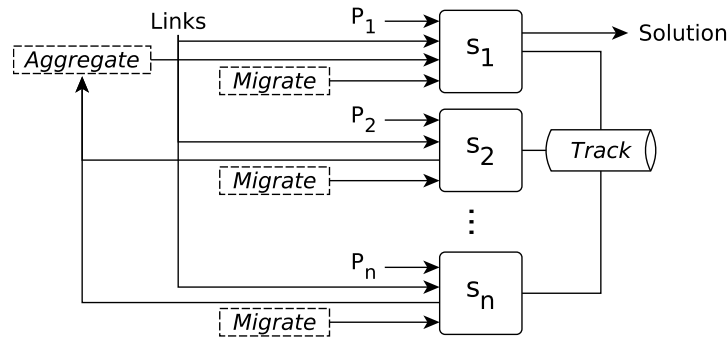
Figure 1: An overview of a *DMAPF* system.

to submit their plan, which constitutes a part of the solution, then it will combine them to produce the final solution.

3.1 Problem Division

Figure 2 shows a set of programs used in problem division. The uses of these programs are controlled by a C++ implementation. First, given a MAPF problem P , as generated by the *ASPRILO* project [6], and the dimension $dx \times dy$ of desired subproblems, program base is called to determine the following atoms:

- $d(D, (X, Y))$ – direction (X, Y) that a robot can move in each time step. D is a number representing the direction, which will be later used in movement planning (Section 3.2.4). In our setting, the robots can move one node at a time to either left, right, up, or down, which correspond to $(-1, 0)$, $(1, 0)$, $(0, -1)$, or $(0, 1)$, respectively.
- $goal(R, N)$ – robot R has its goal at node N . To restrict each robot to have at most one distinct goal, we assume that there is **at most** one order per robot, where the order is to pick a distinct product P on a distinct shelf S , which is at node N at coordinate C .

Subproblems are determined in an iterative manner. Suppose x_{min} , x_{max} , y_{min} , and y_{max} are the left, right, top, and bottom-most points of a given problem P , there would be a total of $\lceil \frac{x_{max}-x_{min}+1}{dx} \rceil \cdot \lceil \frac{y_{max}-y_{min}+1}{dy} \rceil$ subproblems (if the map is rectangular). The map of the top-left subproblem would be bounded within the range of $x = [x_{min}, x_{min} + dx)$ and $y = [y_{min}, y_{min} + dy)$. The boundaries of the other subproblems can be determined by adjusting x_{min} , x_{max} (resp. y_{min} , y_{max}) by dx (resp. dy). Program

```

#program base.
d(0,(-1,0)). d(1,(1,0)). d(2,(0,-1)). d(3,(0,1)).
goal(R,N) :- init(object(order,R),value(line,(P,_))),
              init(object(product,P),value(on,(S,_))),
              init(object(shelf,S),value(at,C)),
              init(object(node,N),value(at,C)).

#program divide(s, x_min, x_max, y_min, y_max).
node(s,N,(X,Y)) :- init(object(node,N),value(at,(X,Y))),
                  X >= x_min, X < x_max, Y >= y_min, Y < y_max.
robot(s,R,N) :- init(object(robot,R),value(at,C)), node(s,N,C).
edge(s,N1,N2) :- node(s,N1,(X,Y)), node(s,N2,(X+DX,Y+DY)), d(_, (DX,DY)).
edge(s,N,N) :- node(s,N,_).
border(s,N) :- node(s,N,(x_min,Y)). border(s,N) :- node(s,N,(x_max-1,Y)).
border(s,N) :- node(s,N,(X,y_min)). border(s,N) :- node(s,N,(X,y_max-1)).

#program link.
link(S1,S2,N1,N2) :- border(S1,N1), border(S2,N2), node(S1,N1,(X,Y)),
                    node(S2,N2,(X+DX,Y+DY)), S1 != S2, d(_, (DX,DY)).

#program result.
i(N,C) :- node(S,N,C), area(S,A,N).
o(N2,C) :- link(S1,S2,N1,N2), area(S1,A,N1), node(S2,N2,C).
x(N1,N2,D) :- area(S,A,N1), area(S,A,N2), node(S,N1,(X1,Y1)),
              node(S,N2,(X2,Y2)), d(D,(X2-X1,Y2-Y1)).
x(N2,N1,D) :- link(S1,S2,N1,N2), area(S1,A,N1), node(S1,N1,(X1,Y1)),
              node(S2,N2,(X2,Y2)), d(D,(X1-X2,Y1-Y2)).
l(N1,C1,N2,C2) :- link(S1,S2,N1,N2), area(S1,A1,N1), node(S1,N1,C1),
                  area(S2,A2,N2), node(S2,N2,C2).
l(A1,A2) :- link(S1,S2,N1,N2), area(S1,A1,N1), area(S2,A2,N2).

```

Figure 2: The collection of programs used for problem division.

`divide` is repeatedly called (with external atoms which we omit) to determine the information pertaining to each subproblem S as follows:

- $node(S, N, C)$ – node N is in subproblem S at coordinate C .
- $robot(S, R, N)$ – robot R starts at node N which is in subproblem S .
- $edge(S, N_1, N_2)$ – nodes N_1 and N_2 are next to each other in subproblem S .
- $border(S, N)$ – node N is a border in subproblem S .

Program `link` is then called after all the subproblems have been created from the calls to program `divide`. It determines the following atom:

- $link(S_1, S_2, N_1, N_2)$ – node N_1 in subproblem S_1 is next to node N_2 in subproblem S_2 . Solvers of S_1 and S_2 are considered to be *neighbors* if there is a link between them.

Atoms $edge/3$ acquired from the calls to program `divide` are used to determined areas within each subproblem. An *area* is a region where the nodes inside are all connected. Atoms $area(S, A, N)$ are added to denote that node N is a part of area A which is in subproblem S . Then, program `result` is repeatedly called (with external atoms which we omit) to determine a set of information pertaining to each area A as follows:

- $i(N, C)$ – node N at coordinate C is in area A .
- $o(N, C)$ – node N at coordinate C is right outside of area A (only one *direction* away).
- $x(N_1, N_2, D)$ – node N_1 is next to node N_2 , and they are in area A . N_1 can be a node in either $i/2$ or $o/2$, but N_2 can only be a node in $i/2$.
- $l(N_1, C_1, N_2, C_2)$ – node N_1 at coordinate C_1 in area A is next to node N_2 at coordinate C_2 in another area.

Each subproblem P_i consists of information about its areas, which includes the atoms acquired from the call to program `result`. Besides the atoms, a subproblem also contains auxiliary information such as the number of nodes in different areas (within the subproblem), a list of its neighboring areas (and their solvers), and a list of nodes that are *corners* (i.e., a node that connects to multiple areas) and the areas which they connect to. A set of atoms $l(A_1, A_2)$, which denotes that areas A_1 and A_2 are connected, is the content of *Links* (in figure 1) which is an input to every solver.

3.2 Problem Solving

After a MAPF problem P has been divided into subproblems P_1, P_2, \dots, P_n as explained in Section 3.1, a solver s_i is created for each subproblem P_i . The solvers s_1, s_2, \dots, s_n execute algorithm 2 in parallel to solve their own subproblem P_i , and at the end s_1 will combine their partial plans to produce the solution of the original problem P . The algorithm requires a few explanations as follows:

1. The lines where the first word is underlined denote that they involve communication with other solvers. Lines 9 and 30 publish a message to the *Track* topic. Lines 15, 17, and 20 send a migration request to the *Migrate* service of the solver that contains area a , for each $a \in Send$. Lines 16, 18, and 21 wait to receive a number of *Migrate* service calls according to the number of areas in *Recv*.

2. The global variables: *Active*, *Send*, and *Recv* (defined at line 1), are determined from the communication between solvers. *Active* keeps track of solvers that still have work to do, i.e., there is a movement plan to be made or there exists a robot that needs to migrate; and has the same content across all the solvers. *Send* (resp. *Recv*) stores areas that s_i needs to send (resp. receive) migration requests to (resp. from). The contents of the variables are determined at lines 9 and 30 by having each solver publishes whether it still has any robot that has not reached its goal (determines *Active*), and if so, which area they would need to leave and enter if the current area does not have their goal (determines *Send* and *Recv*). Every solver (and area) can be uniquely identified by a number (i.e., an ID). A solver (resp. area) with an ID i is denoted as s_i (resp. a_i). For every pair of solvers s_i and s_j , if $i < j$, then all areas in s_i also have smaller IDs than those in s_j . When a solver s_i wants to send a service request to another solver s_j , it can only do so if $i < j$ – this does not mean that s_j cannot send information to s_i , as it can do so in the response message – RPC style. This design ensures that there is only one direction of service calls between each pair of neighboring solvers, thus reducing the overhead in communication by half.
3. Function A (defined at line 2) maps a round (denoted as a number starting from 0) to a set of area instances. An *area instance* (or *instance*, for short) consists of necessary information about everything in the area such as nodes, corners, border assignment constraints, current robots (R), outgoing robots (R_i), incoming robots (R_o), and a movement plan. An instance can be constructed either from either (i) an *area*, as obtained after the problem division (line 4 and 10); or (ii) another instance (lines 22 and 31). When an instance α_2 is constructed from another instance α_1 , the information about the robots in α_2 is determined from α_1 as $\alpha_2.R = (\alpha_1.R \setminus \alpha_1.R_o) \cup \alpha_1.R_i$. The other information is straightforward to determine, so we omit the details. Lines 10 deals with the case where an instance α for area a has not been constructed (because area a contains no robot), but there are some robot in another area that wants to migrate to a – so α needs to be constructed. Line 31 deals with the case where an instance α_2 needs to be constructed based on another instance α_1 of the same area a in the most recent previous round; the problem is, α_1 may not have been constructed at all. If such case happens, α_2 would be constructed from area a .

The algorithm revolves around the notions of (i) abstract planning (line 6); (ii) migration; and (iii) movement planning (line 19). The migration process is divided into three steps: (i) negotiation (lines 15-16); (ii) rejection (lines 17-18); and (iii) confirmation (lines 20-21). The details of each notion will be explained sequentially – as how the algorithm works – in the following subsections.

3.2.1 Abstract Planning

An *abstract plan* is a sequence of connected areas that takes a robot from its initial area to reach the area that contains its goal. The program shown in figure 3 is used to make an abstract plan for a robot r . $r(A, I)$ denotes that r is in area A at round I ; and $g(A)$ denotes that the goal of r is in area A . Program $\text{abstract}(i)$ is solved sequentially from $i = 0, \dots, h_a$ or until an answer set is found. If no answer set is found after $i = h_a$, then we consider there is no way for r to reach its goal, and the algorithm terminates. h_a is set to be the total number of areas across all the subproblems, so an abstract plan has to exist if it is possible for a robot to reach its goal (without considering the other robots).

3.2.2 Negotiation

Negotiation is the first phase of the migration process. Its purpose is to find a set of distinct border assignments for migrating robots. The program shown in figure 4 is used to make such assignments. It

Algorithm 2 *Solve*

Input: $P_i, Links$ **Output:** A solution or none**Parameters:** s_i – a number denoting this solver

```

1: global  $Active = Send = Recv = \{\}$ 
2:  $A = \{\}$ 
3: for each area  $a$  in  $P_i$  that exists a robot do
4:    $A = A \cup \{(0, \alpha)\}$  where an instance  $\alpha$  is constructed from  $a$ 
5:   for each robot  $r$  in  $\alpha$  do
6:     Create an abstract plan for  $r$  using  $Links$  as an abstract map
7:   end for
8: end for
9: Determine  $Active, Send,$  and  $Recv$  from  $A(0)$  of all the solvers
10:  $A = A \cup \{(0, \alpha)\}$  where an instance  $\alpha$  is constructed from an area  $a$  (resp.  $b$ ) that will be sending
    (resp. receiving) a request to (resp. from) the solver of area  $c \in Send$  (resp.  $d \in Recv$ ) – where such
    an instance has not been created
11:
12:  $i = 0$ 
13: while true do
14:   if  $s_i \in Active$  then
15:     Send a negotiation request to the solver of area  $a$  for each  $a \in Send$ 
16:     Wait until  $|Recv|$  negotiation requests have been received
17:     Send a rejection request to the solver of area  $a$  for each  $a \in Send$ 
18:     Wait until  $|Recv|$  rejection requests have been received
19:     Make a movement plan for each instance in  $A(i)$ 
20:     Send a confirmation request to the solver of area  $a$  for each  $a \in Send$ 
21:     Wait until  $|Recv|$  confirmation requests have been received
22:      $A = A \cup \{(i + 1, \alpha_{i+1})\}$  where an instance  $\alpha_{i+1}$  is constructed from  $\alpha_i \in A(i)$  if there exists a
        robot in  $\alpha_i$  that still needs to move
23:   else
24:     Wait for active solvers to finish their work
25:   end if
26:
27:   if  $Active = \emptyset$  then
28:     return  $solution \leftarrow$  aggregated partial plans from all the solvers
29:   else
30:     Determine  $Active, Send,$  and  $Recv$  from  $A(i + 1)$  of all the solvers
31:      $A = A \cup \{(i + 1, \alpha_{i+1})\}$  where an instance  $\alpha_{i+1}$  is constructed from an instance  $\alpha_j$  of area  $a$ 
        (resp.  $\beta_j$  of area  $b$ ) for the most recent round  $j$  where  $\alpha_j$  (resp.  $\beta_j$ )  $\in A(j)$ , and  $a$  (resp.  $b$ )
        will be sending (resp. receiving) a request to (resp. from) the solver of area  $c \in Send$  (resp.
         $d \in Recv$ ) – where such an instance (i.e.,  $\alpha_{i+1}$ ) has not been created; if such  $j$  does not exist,
        then  $\alpha_{i+1}$  is constructed from  $a$  (resp.  $b$ )
32:      $i = i + 1$ 
33:   end if
34: end while

```

```

#program abstract(i).
#external q(i).
1 { r(A2,i) : l(A1,A2) } 1 :- r(A1,i-1).
:- q(i), not r(A,i), g(A).
#show r/2.

```

Figure 3: The program to make an abstract plan for a single robot.

is designed to minimize *makespan* – the time step that all robots reach their goal. When a solver s_1 of an area a_1 sends a negotiation request to a neighboring solver s_2 of an area a_2 , the message contains a set of robots that want to migrate, called $a_1.R_m$, with their current location, grouped and ordered by the number of steps left in their abstract plan to reach the last area (longest first); the result of the grouping will be referred to as *tier*. After s_2 receives the request from s_1 , it merges $a_1.R_m$ with $a_2.R_m$ and orders them by tier from high to low; the result of the merging will be referred to as R_m . It then computes two variables: the number of incoming (resp. outgoing) borders available, n_{ai} (resp. n_{ao}). Let n_l , n_{bi} , and n_{bo} denote the number of pairs of connected borders between a_1 and a_2 , the number of incoming borders that have been blocked, and the number of outgoing borders that have been blocked, respectively, then $n_{ai} = n_l - n_{bi}$, and $n_{ao} = n_l - n_{bo}$. Then, s_2 goes through R_m tier-by-tier. In each tier, if the robots are in a_2 , then they are used to create either atoms $a/2$ or $b/2$; otherwise, they are used to create either atoms $c/2$ or $d/2$. Atoms $a/2$, $b/2$, $c/2$, and $d/2$ in program *migrate* denote the current location of a robot. Whether to encode the robots in $a/2$ (resp. $c/2$) or $b/2$ (resp. $d/2$) depends on the current number of robots that have been assigned out (resp. in), which we will refer to as n_o (resp. n_i). If the number of robots in the tier is less than or equal to n_o (resp. n_i), then they are used to create $a/2$ (resp. $c/2$); otherwise, they are used to create $b/2$ (resp. $d/2$). After the robots in the considering tier have been used to create the atoms, then the value of either n_o or n_i is increased by the number of robots added accordingly, and the tier is removed from R_m . s_2 will stop going through R_m when either (i) $R_m = \emptyset$; or (ii) $n_o \geq n_{ao}$ and $n_i \geq n_{ai}$. The atom $l(L)$ in program *migrate* denotes the limit – the number of robots expected to get the border assigned. L could be calculated as $\min(\min(n_i, n_{ai}) + \min(n_o, n_{ao}), \max(n_{ai}, n_{ao}))$. A collection of atoms $m(R, N_1, N_2, D)$, where it denotes that robot R can migrate from border N_1 in its current area to border N_2 in another area and the distance from its current node to N_1 is D , is obtained from program *migrate*. Each atom $m/4$ is checked whether R is in area a_1 or a_2 . N_1 if $R \in a_2$ (resp. N_2 if $R \in a_1$) is checked whether it is a *corner* node (i.e., a node that connects to more than two areas); if so, a constraint $:- m(_, N_1, _, _)$. (resp. $:- m(_, _, N_2, _)$.) will be added, and the value of n_{bo} (resp. n_{bi}) is increased by one. These constraints prevent s_2 from making border assignments for the next negotiation requests (within the same round) that would result in conflict at the corners. Finally, s_2 remembers the resulting border assignments and also send them to the caller, s_1 .

3.2.3 Rejection

Rejection is the second phase of the migration process. Its purpose is to prevent collision at corners that reside between areas with lower and higher IDs. Suppose there are three solvers: s_1 , s_2 , and s_3 , which contain areas a_1 , a_2 , and a_3 , respectively; two connected pairs of the areas: (1) a_1 and a_2 , and (2) a_2 and a_3 ; and a corner c in a_2 that connects to both a_1 and a_3 . In the negotiation phase, if there are robots from a_1 and a_3 that want to migrate to a_2 , there would be requests from s_1 to s_2 , and from s_2 to s_3 . s_2 (resp. s_3) will take care of border assignment between a_1 and a_2 (resp. a_2 and a_3). This could result in a collision

```

#program migrate.
1 { m(R,N2,N3,|X1-X2|+|Y1-Y2|) : l(N2,(X2,Y2),N3,C3) } 1 :- a(R,(X1,Y1)).
0 { m(R,N2,N3,|X1-X2|+|Y1-Y2|) : l(N2,(X2,Y2),N3,C3) } 1 :- b(R,(X1,Y1)).
1 { m(R,N2,N3,|X1-X2|+|Y1-Y2|) : l(N3,C3,N2,(X2,Y2)) } 1 :- c(R,(X1,Y1)).
0 { m(R,N2,N3,|X1-X2|+|Y1-Y2|) : l(N3,C3,N2,(X2,Y2)) } 1 :- d(R,(X1,Y1)).
:- m(R1,N,_,_), m(R2,N,_,_), R1!=R2.
:- m(R1,_,N,_), m(R2,_,N,_), R1!=R2.
:- m(.,N1,N2,.), m(.,N2,N1,.).
:- C = #count { R : m(R,_,_,_) }, C!=L, l(L).
d(S) :- S = #sum { D : m(.,_,_,D) }.
#minimize { S : d(S) }.
#show m/4.

```

Figure 4: The program to make border assignments for multiple robots.

at c because s_3 would not know which borders s_2 has assigned for the robots in a_1 to come into a_2 – the corner c could be among them. The collision will happen if s_3 also assigns a robot in a_3 to come into a_2 at c . In the rejection phase, every active solver checks for this case and report to the neighboring solvers their robots that will cause the collision. The reported solvers will keep the robots in their area for the current round and attempt to migrate them again in the next round, while the reporting solvers will treat them as not coming in (in this round).

3.2.4 Movement Planning

A *movement plan* is a sequence of movements for robots to reach their goal without collision. The program shown in figure 5 is used by every active solver to make a movement plan for its area that exists some robot that has not reached its goal or assigned border yet. It is similar to the encoding used by the *ASPRILO* project [6], except that it has the following constraints:

- $:- r(R,N,0), o(N,_) , \text{not } m(R,_,_,1), q(t)$. – forces incoming robots to move into the area at the first time step ($t = 1$).
- $:- q(t), g(t), r(R,N,t), c(N), \text{not } g(R,N)$. – prohibits robots to stay at any node that will be migrated into unless it is their goal.

The second constraint helps to increase the success rate of *DMAFF*, but it could make movement planning unsuccessful unless there is sufficient free spaces in the area to enforce it. Therefore, we only add atoms $c(N)$ when $(n_a - n_r - n_i) \geq n_f$, where, for an area a ; n_a, n_m, n_i , and n_f denote the number of nodes; the number of robots currently in it; the number of robots assigned to come in; and the minimum number of free nodes required, set by the user (currently $n_f = 4$), respectively. Most of the atoms come directly from P_i , except:

- $r(R,N,T)$ – robot R is at node N at time step T . An atom $r(R,N_0,0)$ needs to be added for each robot R in the area to denote its starting node N_0 .
- $c(N)$ – denotes that there will be a robot migrating into node N in the next round. The set of such nodes is determined from the result of the *negotiation* and the *rejection* phases.

```

#program movement(t).
#external q(t).
{ m(R,D,N2,t) : x(N1,N2,D) } :- r(R,N1,t-1).
:- m(R,D1,_,t), m(R,D2,_,t), D1 != D2.
:- r(R,N,0), o(N,_), not m(R,_,_,1), q(t).
r(R,N2,t) :- r(R,N1,t-1), m(R,D,N2,t), x(N1,N2,D).
r(R,N,t) :- r(R,N,t-1), not m(R,_,_,t).
w(N1,N2,t) :- r(R,N1,t-1), m(R,D,N2,t), x(N1,N2,D).
:- w(N1,N2,t), w(N2,N1,t).
:- { r(_,N,t) } > 1, i(N,_).
g(t) :- r(R,N,t) : g(R,N).
:- q(t), not g(t).
:- q(t), g(t), r(R,N,t), c(N), not g(R,N).
#show m/4.

```

Figure 5: The program to make a movement plan for multiple robots.

Program `movement(t)` is solved sequentially from $i = 0, \dots, h_m$ or until an answer set is found. h_m is set to $(\sqrt{n_a} + 1) \cdot 2.0 \cdot F$, where n_a is the number of nodes in area a , and F is a sensitivity constant set by the user (currently $F = 2$). The lower the value of F is, the less chance that a movement plan will be found, but it could terminate earlier if there is actually no plan, and vice versa. If no answer set is found after $i = h_m$, then we consider it to be impossible to make a movement plan for the given configuration, and *DMPF* will try to relax the configuration by removing the goal of a migrating robot one at a time, ordered by the Manhattan distance of the robot to its assigned border (longest first), and restarts the call to the program from $t = 0$. *DMPF* terminates (and returns no solution) if it cannot relax the configuration any further.

3.2.5 Confirmation

Confirmation is the third, and the last phase of the migration process. After every active solver has finished movement planning, it will send the information of all the robots that are actually able to move out to the next area, in the neighboring solver, accordingly. The information of the robots remains mostly the same, except that their abstract plan will be shorten by one step because the current area will be removed as they have already been able to move out, and their current location is updated to the border node that they will be migrating from.

4 Experiment

Table 1 provides comparison between three MAPF solvers: (i) *DMPF*; (ii) *ros-dmapf* [10]; and (iii) *ECBS*⁴ [2] – a relaxed version of *CBS* [12] where the solution quality is bounded-suboptimal instead of optimal. We also tried *asprilo* [6] – an ASP encoding that solves MAPF problems optimally – but it cannot solve any of the problem instances within the timeout, so it has been excluded from the table. There are 15 problem configurations according to each row. Their map size is denoted in the first column (from the left). Each configuration contains a different number of robots according to the second column

⁴<https://github.com/whoenig/libMultiRobotPlanning>

Map	n_R	<i>DMAPF</i>			<i>ros-dmapf</i>			<i>ECBS</i>		
		Time	Span	Moves	Time	Span	Moves	Time	Span	Moves
24 x 24	23	2.5	41	443	1.6	46	419	0.1	38	412
	46	2.6	44	960	1.8	58	884	0.1	39	797
	69	2.8	51	1432	2.0	69	1278	0.7	40	1132
	92	3.6	57	2119	2.2	80	1883	1.4	40	1574
	120	3.9	61	2751	2.5	82	2595	2.5	39	1973
48 x 48	92	6.8	104	2890	3.8	118	2768	2.2	76	2651
	184	9.8	117	6815	4.9	137	6625	11.8	81	5929
	276	10.4	128	11683	7.7	187	11223	87.7	87	9387
	368	13.2	124	16090	8.3	187	15858	191.7	86	12481
	460	15.6	125	20920	11.0	210	20428	-	-	-
96 x 96	369	31.8	225	25041	30.0	242	24513	-	-	-
	737	41.7	240	52916	-	-	-	-	-	-
	1106	61.8	280	88943	-	-	-	-	-	-
	1474	83.2	282	124374	-	-	-	-	-	-
	1843	175.4	282	165573	-	-	-	-	-	-

Table 1: Comparison between *DMAPF*, *ros-dmapf*, and *ECBS*. The timeout is 180 seconds.

(n_R), and each robot is randomly assigned a different goal location. The problem instances do not include obstacles because we would be unable to compare with *ros-dmapf* since it does not support having obstacles. The last three main columns contain results from the three solvers, which are *Time* – the solving time in seconds; *Span* – makespan of the solution; and *Moves* – the total number of moves from all the robots. The size of subproblems for both *DMAPF* and *ros-dmapf* is set to 8x8. The suboptimality bound for *ECBS* is set to 1.2. The tests were performed on Ubuntu 20.04 with *Clingo* 5.5.0, running on a Dell Precision-3630 Tower with Intel i9-9900K CPU and 64 GB of RAM.

5 Conclusion and Discussion

The experiment in Section 4 shows that, while *ECBS* performs very fast on the small problem instances, its performance becomes noticeably worse in a 48x48 map with 276 robots, and is unable to find the solution within the timeout in the bigger problems. *ros-dmapf* is generally slightly faster than *DMAPF*, but it is due to its simpler solver interaction protocol. It is unable to scale further when the maps get denser – in terms of the ratio between the number of robots to the number of borders within an area. When this ratio increases, there is more chance for border assignments that will result in no movement plan to be selected. Since *ros-dmapf* randomly assigns borders to migrating robots and cannot change the assignment afterwards, it has difficulties to scale further. The resulting makespan of *DMAPF* is consistent, and better than *ros-dmapf* due to the better border assignment mechanism, but it comes with a slight increase in the number of moves. The solution quality of *ECBS* is still better than the other two solvers due to its centralized nature, but not by much in many cases. We believe *DMAPF* can scale further given a better hardware and/or the use of clusters. To scale *DMAPF* even further, the question whether it is feasible to also backtrack when movement planning fails even after all the relaxation should be addressed. Mechanisms that can balance the density of robots across the areas may also be helpful.

References

- [1] Benjamin Andres, David Rajaratnam, Orkunt Sabuncu & Torsten Schaub (2015): *Integrating ASP into ROS for Reasoning in Robots*. In: *Proceedings of the 13th International Conference on Logic Programming and Nonmonotonic Reasoning*, 9345, Springer, Lexington, Kentucky, pp. 69–82, doi:10.1007/978-3-319-23264-5_7.
- [2] Max Barer, Guni Sharon, Roni Stern & Ariel Felner (2014): *Suboptimal Variants of the Conflict-Based Search Algorithm for the Multi-Agent Pathfinding Problem*. In: *Seventh Annual Symposium on Combinatorial Search*, doi:10.3233/978-1-61499-419-0-961.
- [3] Simona Citrigno, Thomas Eiter, Wolfgang Faber, Georg Gottlob, Christoph Koch, Nicola Leone, Cristinel Mateis, Gerald Pfeifer & Francesco Scarcello (1997): *The dlv System: Model Generator and Application Frontends*. In: *Proceedings of the 12th Workshop on Logic Programming*, 128137, pp. 128–137. Available at <https://www.wfaber.com/research/papers/wlp97.pdf>.
- [4] Martin Gebser, Roland Kaminski, Benjamin Kaufmann & Torsten Schaub (2014): *Clingo = ASP + Control: Preliminary Report*. In: *Technical Communications of the 13th International Conference on Logic Programming*, 14(4-5). Available at <https://arxiv.org/abs/1405.3694>.
- [5] Martin Gebser, Benjamin Kaufmann, André Neumann & Torsten Schaub (2007): *clasp : A Conflict-Driven Answer Set Solver*. In: *Proceedings of the 9th International Conference on Logic Programming and Nonmonotonic Reasoning*, 4483, Springer, Tempe, Arizona, pp. 260–265, doi:10.1007/978-3-540-72200-7_23.
- [6] Martin Gebser, Philipp Obermeier, Thomas Otto, Schaub Torsten, Orkunt Sabuncu, Van Nguyen & Tran Cao Son (2018): *Experimenting with robotic intra-logistics domains*. *Theory and Practice of Logic Programming* 18(3-4), pp. 502–519, doi:10.1017/S1471068418000200.
- [7] Michael Gelfond & Vladimir Lifschitz (1990): *Logic Programs with Classical Negation*. In: *Logic Programming, Proceedings of the Seventh International Conference*, MIT Press, Jerusalem, Israel, pp. 579–597. Available at <https://dl.acm.org/doi/10.5555/87961.88030>.
- [8] Victor W. Marek & Mirosław Truszczyński (1999): *Stable Models and an Alternative Logic Programming Paradigm*. In: *The Logic Programming Paradigm - A 25-Year Perspective*, Springer, pp. 375–398, doi:10.1007/978-3-642-60085-2_17.
- [9] Ilkka Niemelä (1999): *Logic Programs with Stable Model Semantics as a Constraint Programming Paradigm*. *Annals of Mathematics and Artificial Intelligence* 25(3-4), pp. 241–273, doi:10.1023/A:1018930122475.
- [10] Poom Pianpak, Tran Cao Son, Z O Toups & William Yeoh (2019): *A Distributed Solver for Multi-Agent Path Finding Problems*. In: *Proceedings of the First International Conference on Distributed Artificial Intelligence*, pp. 1–7, doi:10.1145/3356464.3357702.
- [11] Morgan Quigley, Ken Conley, Brian Gerkey, Josh Faust, Tully Foote, Jeremy Leibs, Rob Wheeler & Andrew Y. Ng (2009): *ROS: an open-source Robot Operating System*. In: *ICRA workshop on open source software*, 3, Kobe, Japan, p. 5. Available at <http://www.cim.mcgill.ca/~dudek/417/Papers/quigley-icra2009-ros.pdf>.
- [12] Guni Sharon, Roni Stern, Ariel Felner & Nathan R. Sturtevant (2015): *Conflict-based search for optimal multi-agent pathfinding*. *Artificial Intelligence* 219, pp. 40–66, doi:10.1016/j.artint.2014.11.006.
- [13] David Silver (2005): *Cooperative Pathfinding*. In: *Proceedings of the 1st Artificial Intelligence and Interactive Digital Entertainment Conference*, 1, Marina Del Rey, pp. 117–122. Available at <https://www.aaai.org/Library/AIIDE/2005/aiide05-020.php>.